

650V N-CHANNEL POWER MOSFET

GENERAL DESCRIPTION

The Power MOSFET is fabricated using advanced super junction technology. The resulting device has extremely low on resistance, making it especially suitable for applications which require superior power density and outstanding efficiency.

Features

- ◆ $V_{DS} = 650V, I_D = 11A$
- ◆ $V_{DS,min@Tj(max)} = 700V$
- ◆ $R_{DS(ON)}$
 TYP: $320m\Omega @ V_{GS} = 10V, I_D = 5.5A$
 MAX: $380m\Omega$

Applications

- ◆ Power factor correction (PFC)
- ◆ Switched mode power supplies (SMPS)
- ◆ Uninterruptible power supply (UPS)
- ◆ LED lighting power

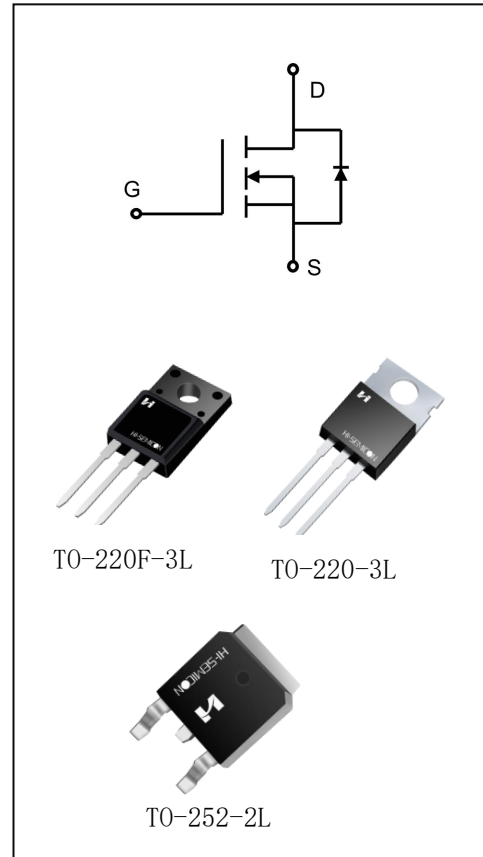

ORDERING INFORMATION

Part No.	Package	Marking	Material	Packing
SCF65R380C	TO-220F-3L	SCF65R380C	Pb Free	Tube
SCP65R380C	TO-220-3L	SCP65R380C	Pb Free	Tube
SCD65R380C	TO-252-2L	SCD65R380C	Pb Free	Reel

ABSOLUTE MAXIMUM RATINGS (T_J=25°C unless otherwise noted)

Characteristics	Symbol	Ratings		Unit
		SCF65R380C	SCP65R380C SCD65R380C	
Drain-Source Voltage	V _{DS}	650		V
Gate-Source Voltage	V _{GS}	±30		V
Drain Current	I _D	T _C = 25°C		A
		T _C = 100°C		
Drain Current Pulsed(Note 1)	I _{DM}	44		A
Power Dissipation(T _C =25°C) -Derate above 25°C	P _D	38	97	W
		0.35	0.74	W/°C
Single Pulsed Avalanche Energy (Note 2)	E _{AS}	251		mJ
Operation Junction Temperature Range	T _J	-55~+150		°C
Storage Temperature Range	T _{stg}	-55~+150		°C
Maximum lead temperature for soldering purposes, 1/8" from case for 5 seconds	TL	300		°C

THERMAL CHARACTERISTICS

Characteristics	Symbol	MAX		Unit
		SCF65R380C	SCP65R380C SCD65R380C	
Thermal Resistance, Junction-to-Case	R _{θJC}	2.9	1.3	°C/W
Thermal Resistance, Junction-to-Ambient	R _{θJA}	62.5	62.5	°C/W

ELECTRICAL CHARACTERISTICS

Characteristics	Symbol	Test conditions	Min.	Typ.	Max.	Unit
Off Characteristics						
Drain-Source Breakdown Voltage	B _{VDS}	V _{GS} =0V, I _D =250μA	650	700	--	V
		V _{GS} =0V, I _D =250μA, T _J =150	700	--	--	
Drain-Source Leakage Current	I _{DSS}	V _{DS} =650V, V _{GS} =0V	--	--	100	nA
Gate-Source Leakage Current	I _{GSS}	V _{GS} =30V, V _{DS} =0V	--	--	100	nA
Gate-Source Leakage Current	I _{GSS}	V _{GS} =-30V, V _{DS} =0V	--	--	-100	nA
On Characteristics						
Gate Threshold Voltage	V _{GS(th)}	V _{GS} = V _{DS} , I _D =250μA	2	3.2	4.0	V
Static Drain- Source On State Resistance	R _{DS(on)}	V _{GS} =10V, I _D =5.5A	--	320	380	mΩ
Forward Transconductance	g _{FS}	V _{DS} =25V, I _D =11A (Note 3)	--	7.4	--	S
Dynamic Characteristics						
Gate Resistance	R _g	V _{GS} =0V; f=1.0MHZ	1	5.5	10	Ω
Input Capacitance	C _{iss}	V _{DS} =100V V _{GS} =0V f=1.0MHZ	--	625	--	pF
Output Capacitance	C _{oss}					
Reverse Transfer Capacitance	C _{rss}		--	2.3	--	pF

Switching Characteristics						
Turn-on Delay Time	$t_{d(on)}$	$V_{DD}=300V; V_{GS}=10V$ $R_G=24\Omega; I_D=11A$ (Note 3.4)	--	11.5	--	ns
Turn-on Rise Time	t_r		--	36.5	--	
Turn-off Delay Time	$t_{d(off)}$		--	65.1	--	
Turn-off Fall Time	t_f		--	30.0	--	
Total Gate Charge	Q_g	$V_{DS}=520V, I_D=11A$ $V_{GS}=10V$ (Note 3.4)	--	18.2	--	nC
Gate-Source Charge	Q_{gs}		--	2.0	--	
Gate-Drain Charge	Q_{gd}		--	11.4	--	

SOURCE-DRAIN DIODE RATINGS AND CHARACTERISTICS

Characteristics	Symbol	Test conditions	Min.	Typ.	Max.	Unit
Continuous Source Current	I_S	Integral Reverse P-N Junction Diode in the MOSFET	--	--	11	A
Pulsed Source Current	I_{SM}		--	--	44	
Diode Forward Voltage	V_{SD}	$I_S=11A, V_{GS}=0V$	--	0.85	1.4	V
Reverse Recovery Time	T_{rr}	$I=11A, V_{GS}=0V,$ $dI/dt=100A/\mu S$ (Note 3)	--	386	--	ns
Reverse Recovery Charge	Q_{rr}		--	4.5	--	μC

NOTE:

1. Pulse width limited by maximum junction temperature
2. $L=79mH, I_{AS}=2.4A, V_{DD}=100V, V_G=10V, R_G=25\Omega,$ starting $T_J=25^\circ C$
3. Pulse Test: Pulse width $\leq 300\mu s,$ Duty cycle $\leq 2\%$
4. Essentially independent of operating temperature

Typical Performance Characteristics

Figure 1. On-Characteristics

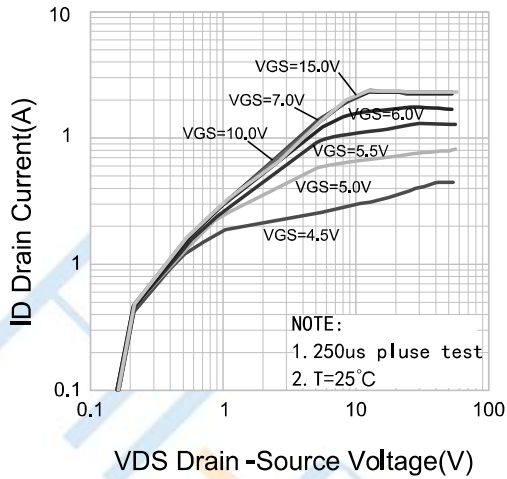

Figure 2. Transfer Characteristics

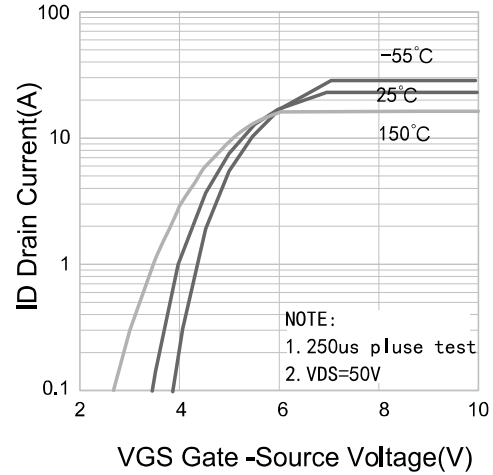

Figure 3. On-Resistance vs Drain Current

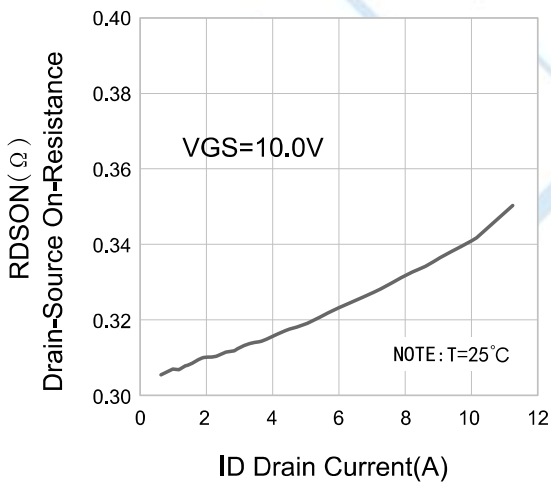

Figure 4. Body Diode Forward Voltage Variation vs Source Current and Temperature

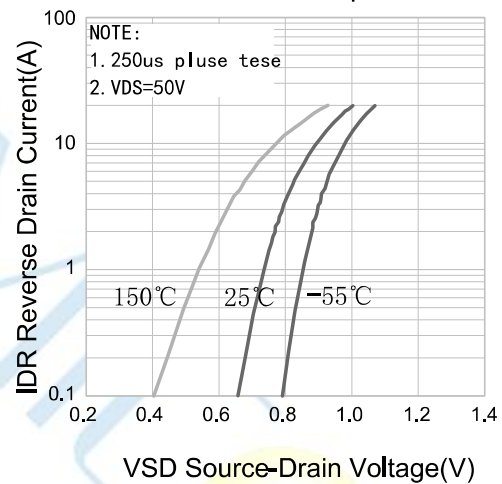

Figure 5. Capacitance Characteristics

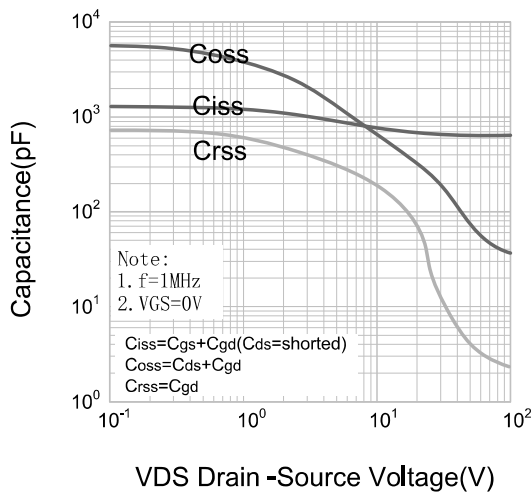
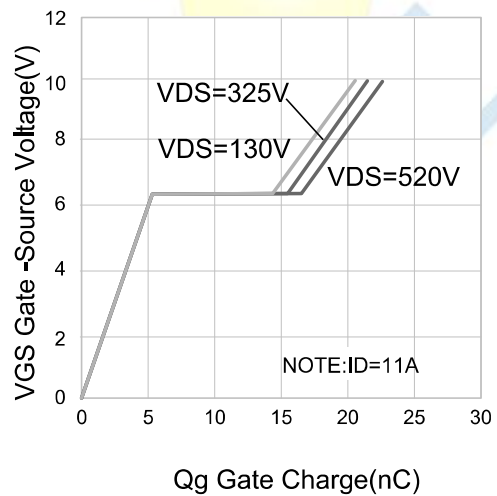

Figure 6. Charge Quantity Characteristics



Typical Performance Characteristics

Figure 7. Breakdown Voltage Variation vs Temperature

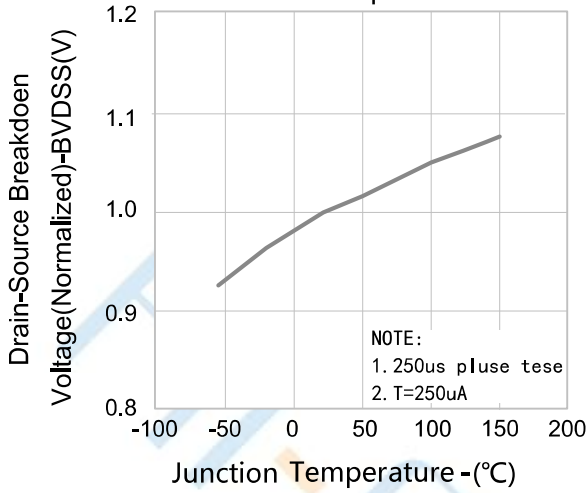

Figure 8. On-resistance Variation vs Temperature

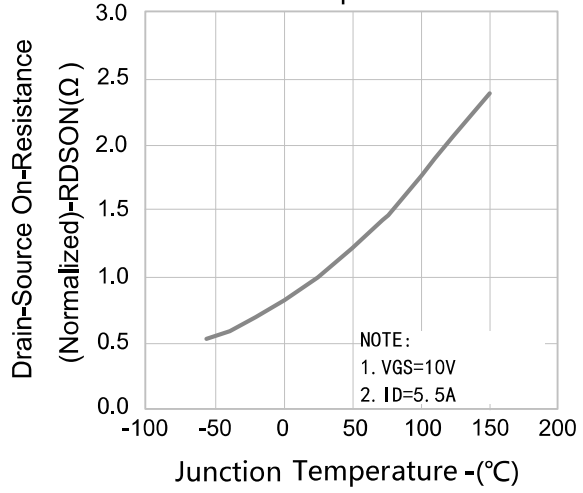

Figure 9-1. Max. Safe Operating Area of SCF65R380C

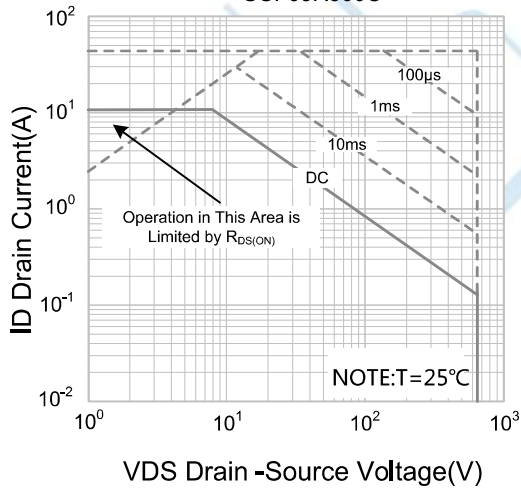

Figure 9-2. Max. Safe Operating Area of SCD65R380C

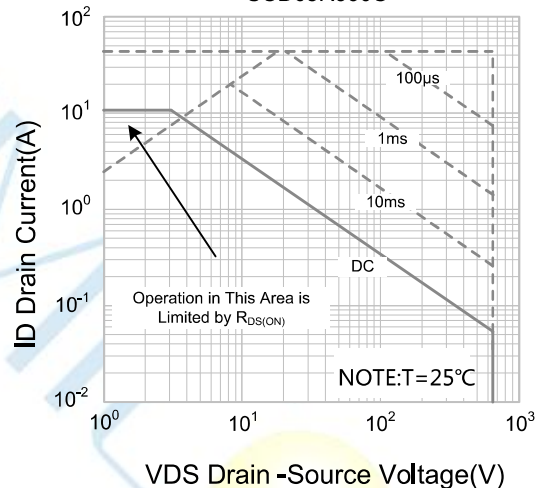
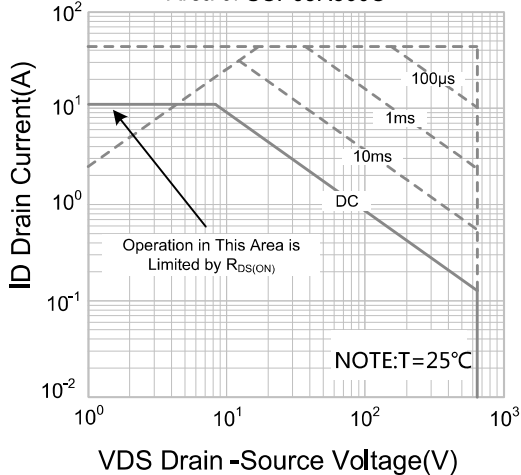
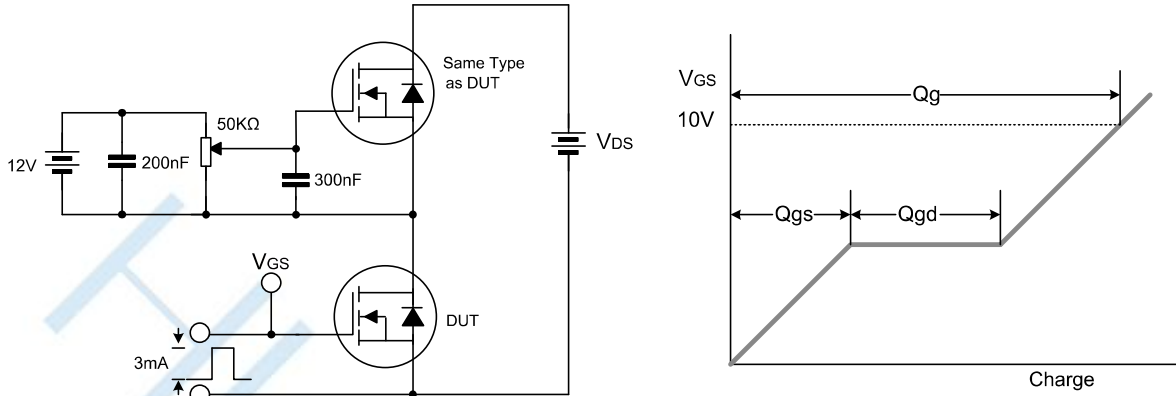

Figure 9-3. Max. Safe Operating Area of SCP65R380C



Test Circuit



Gate Charge Test Circuit & Waveform

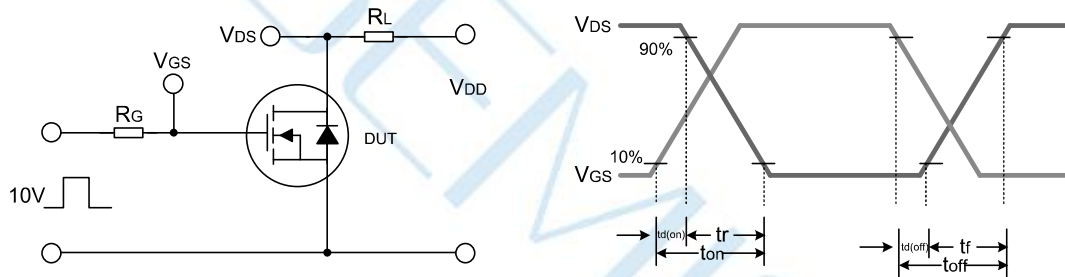

Resistive Switching Test Circuit & Waveform

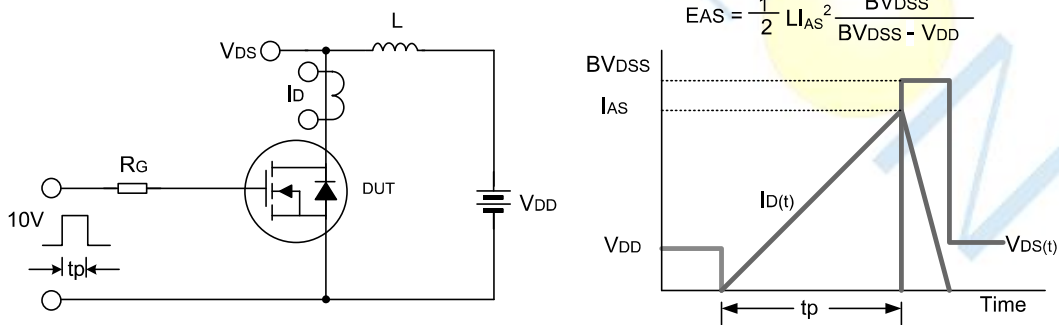

EAS Test Circuit & Waveform

Package Dimensions of TO-220F-3L

Unit:mm

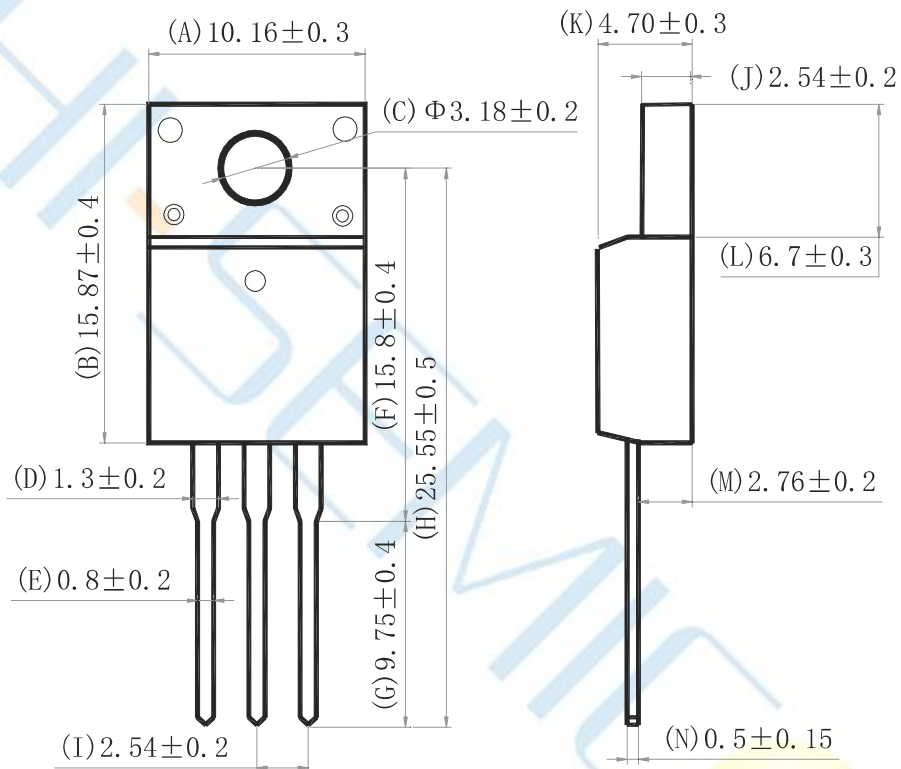

Package Dimensions of TO-220-3L

Unit:mm

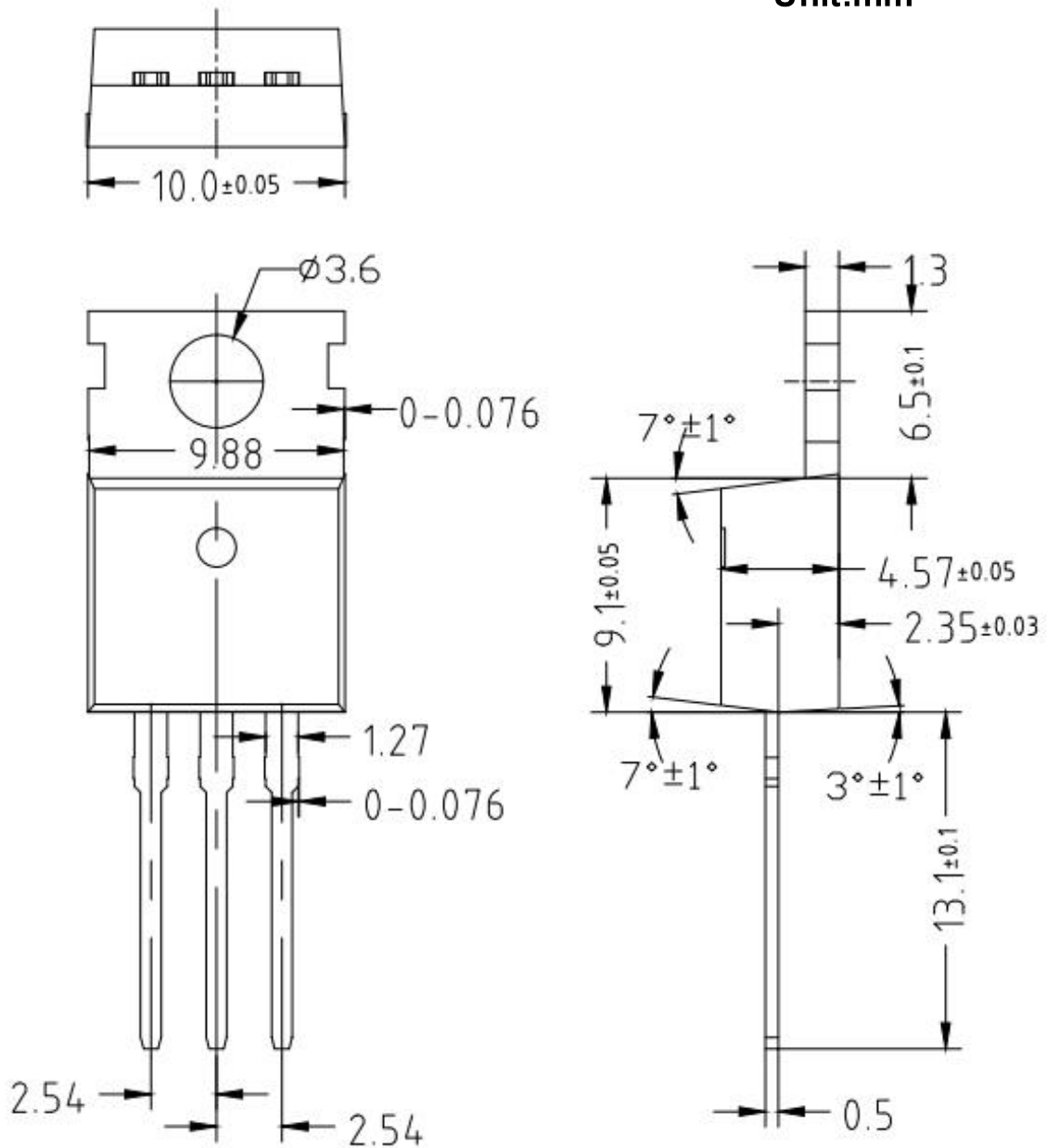

Package Dimensions of TO-252-2L

Unit:mm

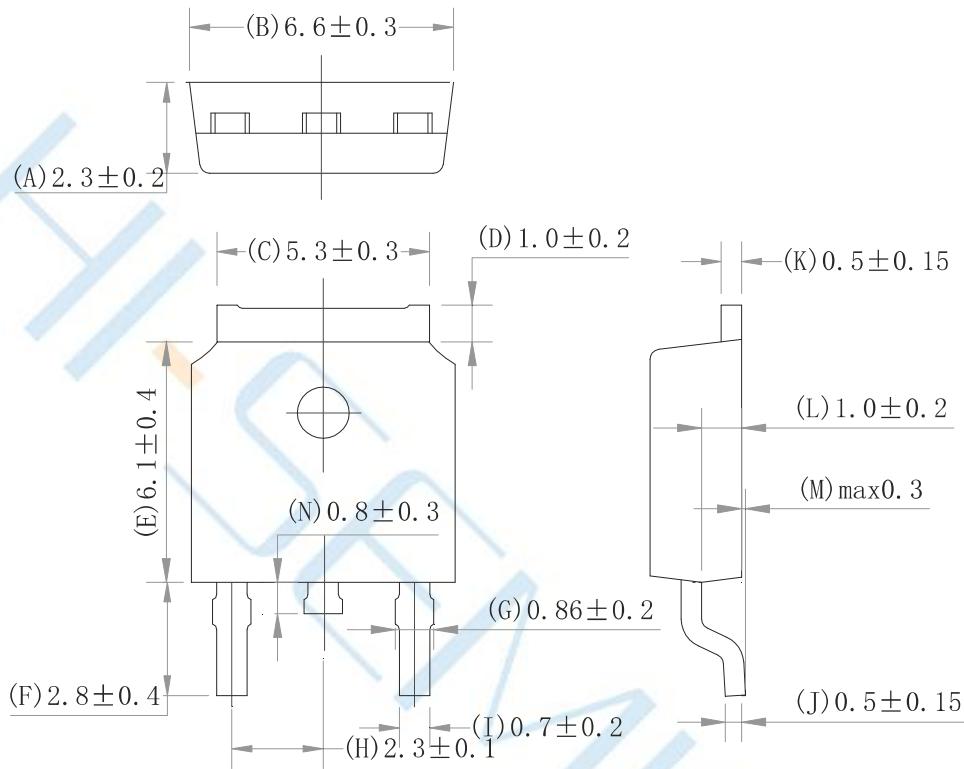

Disclaimer:

- ▶ Hi-semicon reserves the right to make changes to the information herein for the improvement of the design and performance without further notice! Customers should obtain the latest relevant information before placing orders and should verify that such information is complete and current.
- ▶ All semiconductor products malfunction or fail with some probability under special conditions. When using Hi-semicon products in system design or complete machine manufacturing, it is the responsibility of the buyer to comply with the safety standards strictly and take essential measures to avoid situations in which a malfunction or failure of such Hi-semicon products could cause loss of body injury or damage to property.
- ▶ Hi-semicon will supply the best possible product for customers!